



*The Musketeer
Group*

INNOVATE | CREATE | EDUCATE

WWW.THEMUSKETEER.IN

OUR BRANDS



The Musketeer Build is a well-known Construction company in Faridabad (India) for both residential and commercial projects. We left strong footprints in the entire spectrum of real estate development, creating and managing projects in Delhi NCR.



“The Musketeer Interiors” is a highly professional and creative Interior Design and Furniture Design firm in Faridabad. We provide our Interior Design services all over NCR. We work in all types of interior arts such as Modern Arts, Classic Arts, Vintage Arts, Luxury Arts, Premium Arts, etc.



The Musketeer Event Planner Is one of the leading Event Companies Specialized in VIP Experience Conferences, Seminar, Private celebrations, Trade Shows, Corporate Events, Festival and Parties.



Ambika Resort

Ambika Resort is not just a resort in Rishikesh that will leave you breathless with the enchantment of its surroundings, but assists in enabling you to experience both physical and mental relaxation.

THE MUSKETEER BUILD

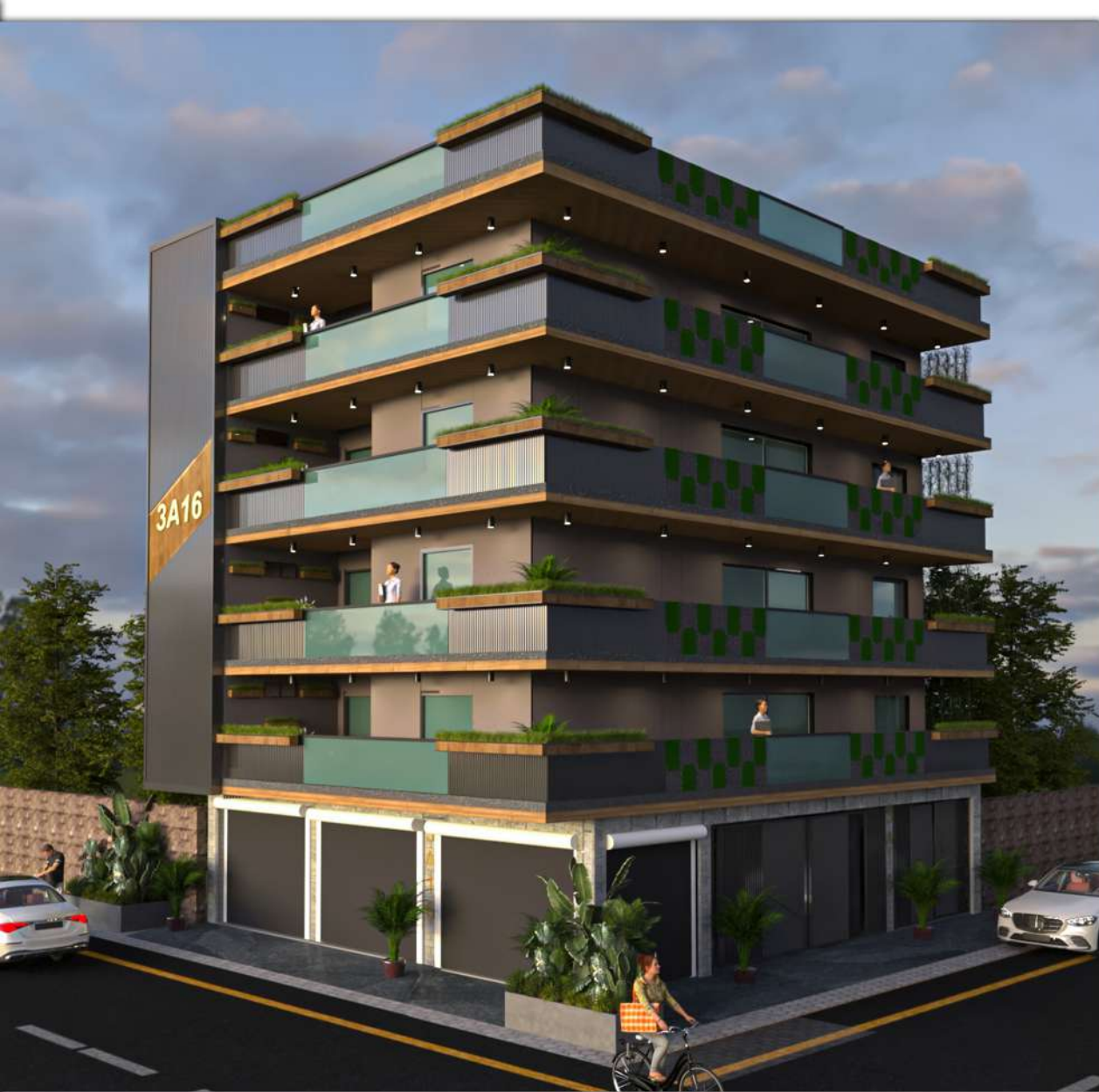

PREMIUM LOCATION OF FARIDABAD



NATURAL LIGHT & VENTILATION AS 95% OF
THE UNITS ARE EAST & WEST FACING



BIG OPEN ENVIRONMENT



COMMUNITY AREA



CLOSE TO REPUTED SCHOOLS, COLLEGES



CLOSE TO REPUTED HOSPITAL

WE BUILD YOUR HAPPINESS

3A16

ARCHITECTURE BY
THE MUSKETEER BUILD



THE MUSKETEER BUILD

3 BHK



BALCONY AREA =
319 sq.ft.
(29.6361 sq.mt.)

UNIT CARPET AREA =
992 sq.ft.
(92.1598 sq.mt)

TOTAL BUILT-UP AREA=
1595 sq.ft.
(148.1803 sq.mt.)

Disclaimer : Unit Plans are not on Scale. In the interest of maintaining high standard, layout, dimensions , specifications and features are indicative and are subject to change as decided by the company or by comptent authority

THE MUSKETEER BUILD

PLUMBING FILE



PLUMBING FILE 3A/16

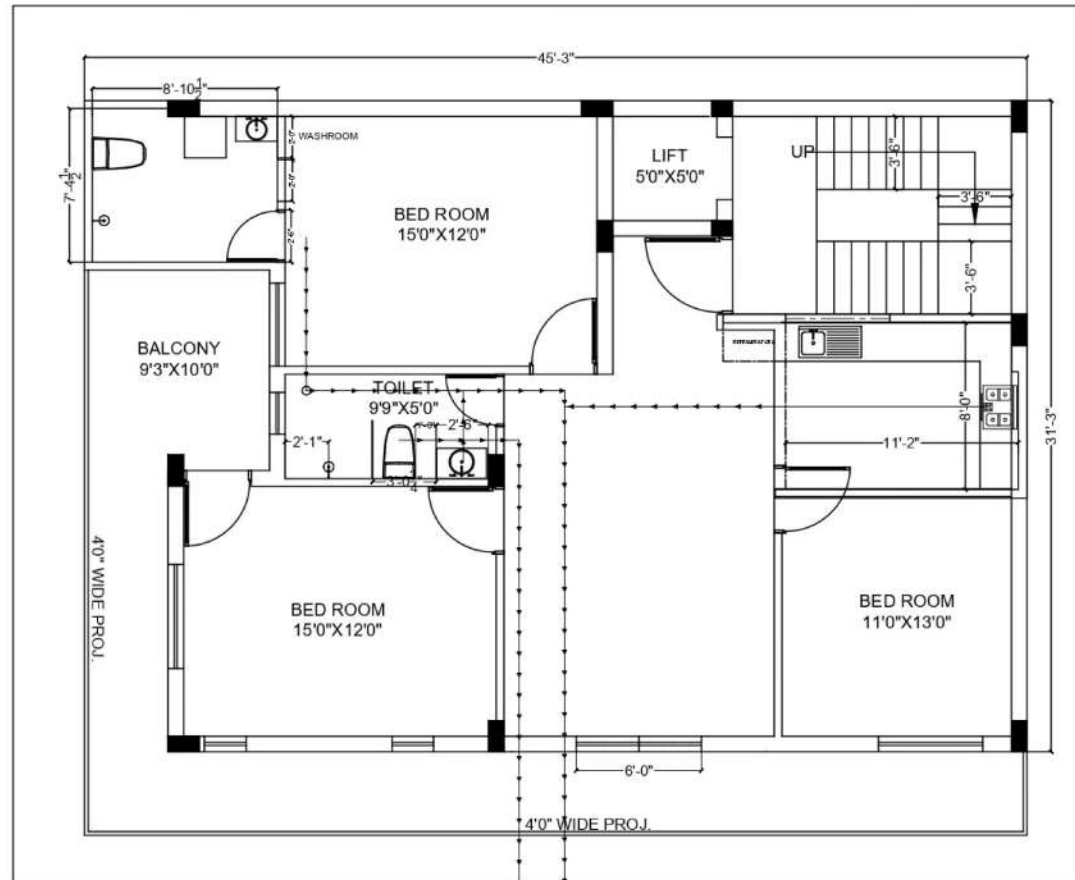

Disclaimer : Unit Plans are not on Scale. In the interest of maintaining high standard, layout, dimensions , specifications and features are indicative and are subject to change as decided by the company or by comptent authority

THE MUSKETEER BUILD

ELECTRICAL PLACING FILE

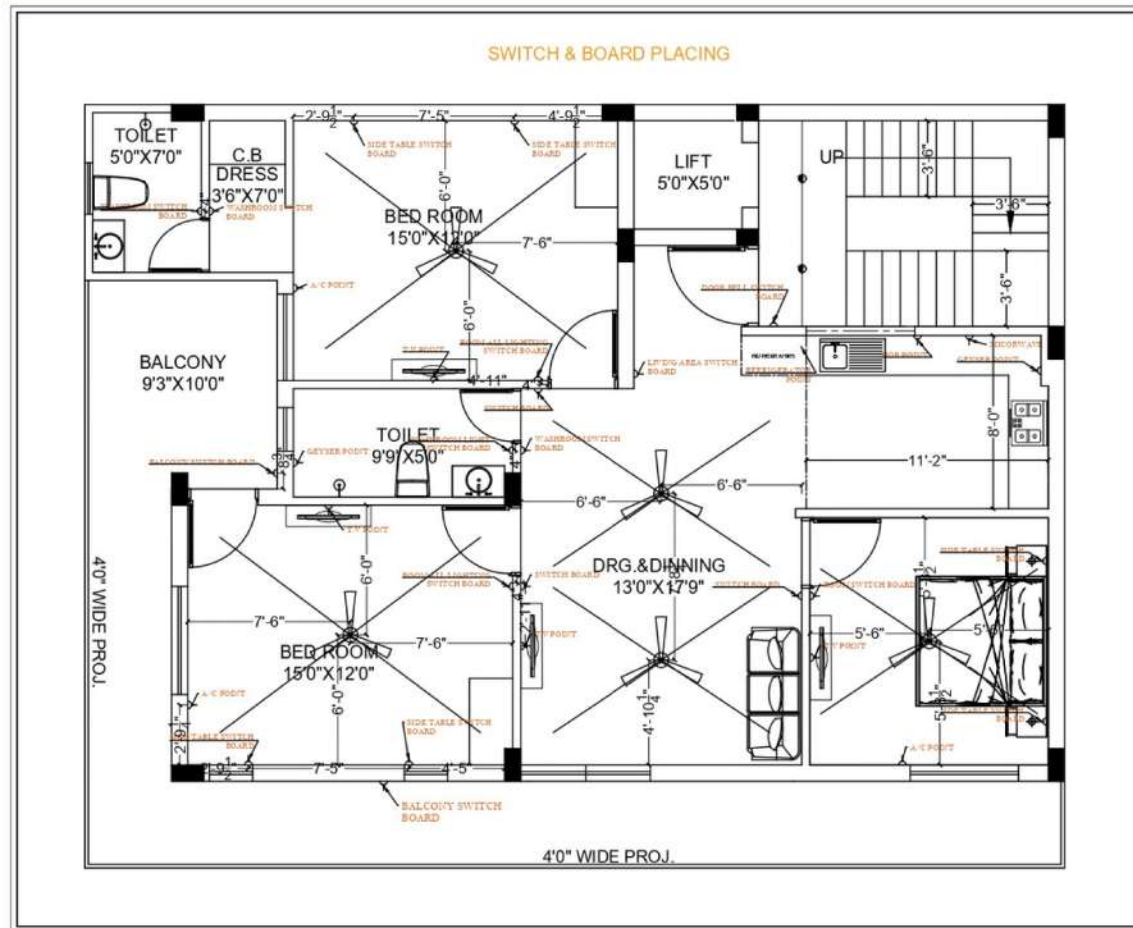

Disclaimer : Unit Plans are not on Scale. In the interest of maintaining high standard, layout, dimensions , specifications and features are indicative and are subject to change as decided by the company or by comptent authority

Every Details will speak the opulence reflecting your outlandish personality

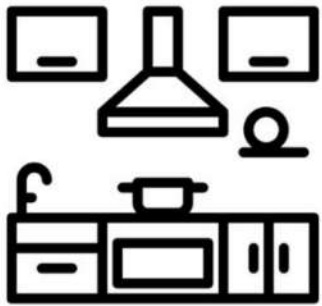

KITCHEN

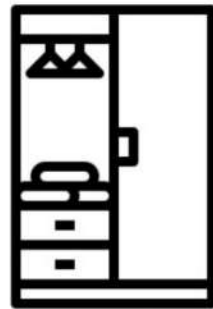

WARDROBE



VANITY



BATHROOM FIXTURE

Kitchen

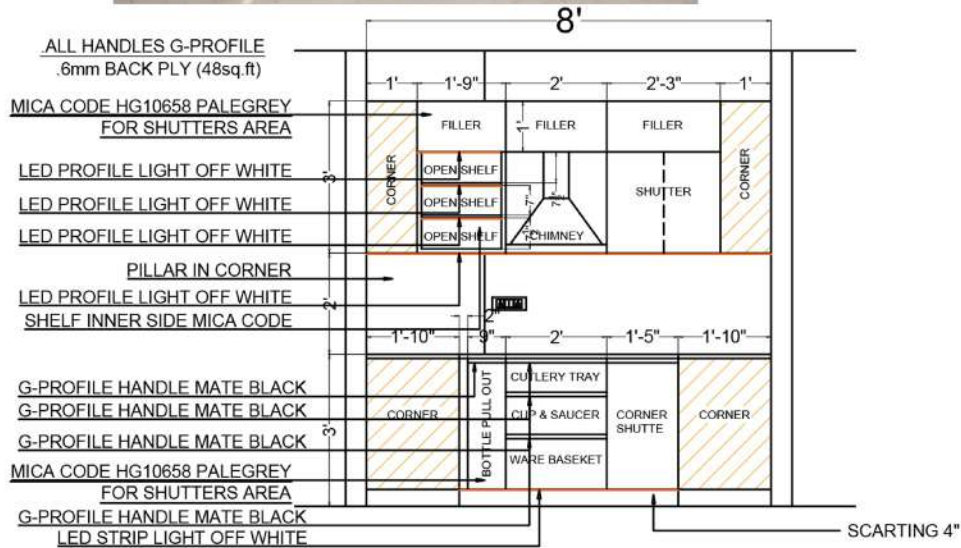

Door

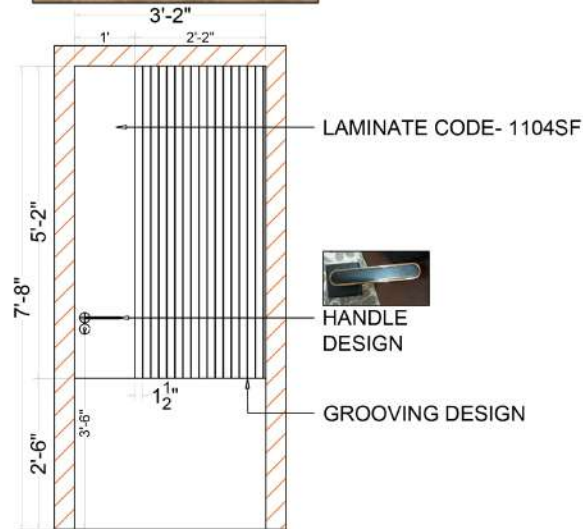

Wardrobe

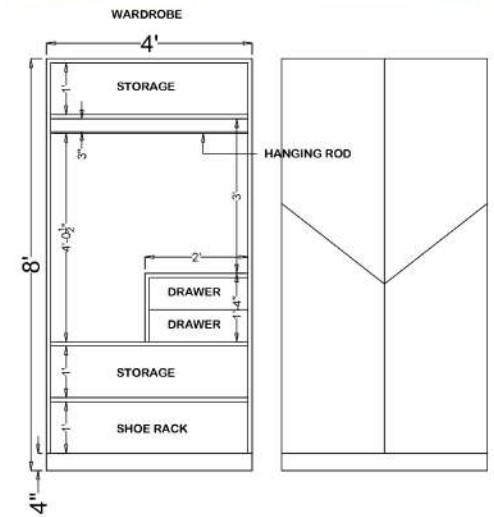

CERA



- F1019452 Single lever basin mixer with 300 mm (12") extended body and 600 mm braided connection pipe (without pop-up)



- F4010108 Push type single lever concealed diverter



- Chrome Plating : Everlasting shine / Easy to clean / Resists stains



- F1013551 Single lever Sink mixer (table mounted) with 235 mm (9") long swivel spout and 450 mm long braided connection pipe



- F7040105 Overhead shower arm 380 mm (15") with wall flange



- F7010504AB Overhead rain shower 100 x 100 mm



- S1044167 Wall hung EWC with duroplast slim seat cover 555 x 370 x 365 mm



- S2020143 Table top wash basin 405 x 405 x 145 mm

LOCATION



Coveted by holistic amenities like education, Shopping, healthcare etc.



**6 MONTH
FREE MAINTENANCE**



**EASY
PAYMENT**



**BANK FINANCE
AVAILABLE**



OUR TEAM



OUR HEADQUATER

5E, 69, Shahid Sukhdev Marg,
Near Satguru Juice Corner,
Faridabad, Haryana 121001



OUR PRODUCTION

Plot no. 1, Jeevan Nagar, Wazirpur
Road, Sector 87, Faridabad, Haryana,
121002



OUR RESORT

Ambika Resort Paliyal Village Ghattu
Ghat, Neelkanth Temple Rd, Rishikesh,
Uttarakhand 249201



THANK YOU



Website

Themusketeerbuild.com



Contact No.

7055705502



Address

5E, 69, Shahid Sukhdev Marg, Near Satguru
Juice Corner, Faridabad, Haryana 121001